

NÚMERO	DESCRIPCIÓN	CÓDIGO
1	CREMALLERA	3000771
2	MOLDURA CUBRE TUBOS DER	2117043
3	MOLDURA CUBRE TUBOS IZQ	2117044
4	DESVIADOR DE AIRE	3078451
5	PATIN POSTERIOR	3039965
6	TACON NIVELADOR	3039966
7	SENSOR TEMPERATURA	3049474
8	INTERRUPTOR MAGNÉTICO	3030429
9	RETEN MAGNÉTICO	3024322
10	CLIP	3042320
11	ARNES TOMACORRIENTE	3000427
12	CONTROL TEMPERATURA	2123890
13	SEPARADOR DE PARED	3001490
14	ADAPTADOR 20W	3067301
15	REJILLA TRASERA GRANDE	2050952
16	REJILLA TRASERA CHICA	2050954
17	PARRILLA	3021044
18	CLIP P/CREMALLERA	3000671
19	REJILLA SEPARADORA	3017003
20	LOUVER	2123919
*	ARNES MAESTRO	3079933
*	ARNES INTERRUPTOR	3059723
*	ARNES JUMPER	3079582
*	ARNES EVAPORADOR	3074720
*	ARNES LED	3079583
*	ARNES UNIDAD	3061531
*	ARNES TIERRA MOTOR	3017532

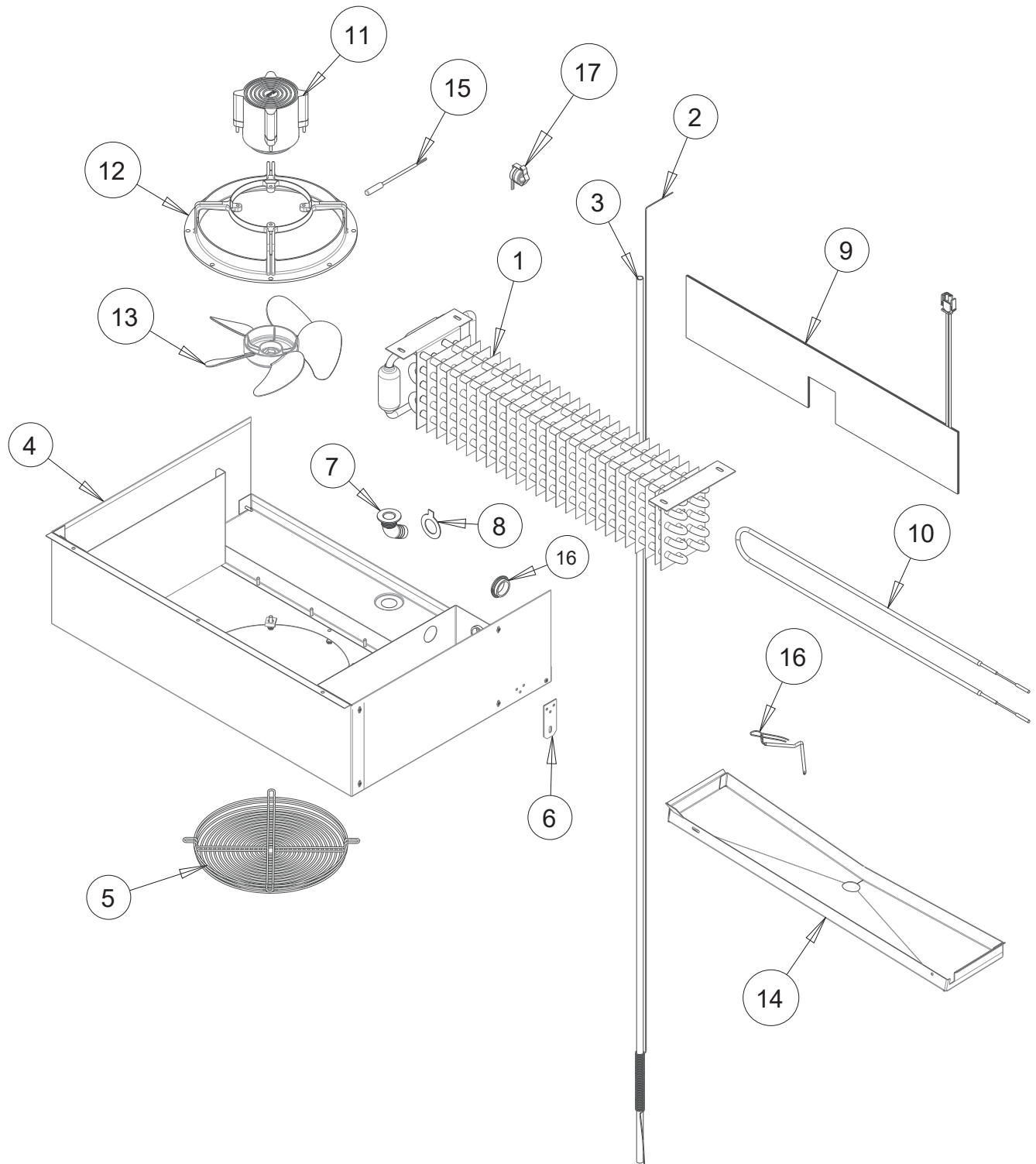

NÚMERO	DESCRIPCIÓN	CÓDIGO
1	EVAPORADOR	3052034
2	TUBO DE RETORNO	2125451
3	TUBO CAPILAR 0.036"X120"	3038210
4	TOLVA	3080991
5	REJILLA EVAPORADOR	3037560
6	SOPORTE TOLVA	3031641
7	COPLÉ	3031064
8	EMPAQUE SCARFT	3046580
9	RESISTENCIA EVAPORADOR 100W	3039664
10	RESISTENCIA 475W	3025584
11	MOTOR EVAP	3069710
12	SOPORTE MOTOR EVAP	3072922
13	ASPA MOTOR EVAP	3024838
14	CHAROLA DE EVAPORACIÓN	3044725
15	SENSOR TEMPERATURA EVAP	3049478
16	RESISTENCIA EVAPORADOR 8.2W	3022615
17	TERMODISCO	3069251

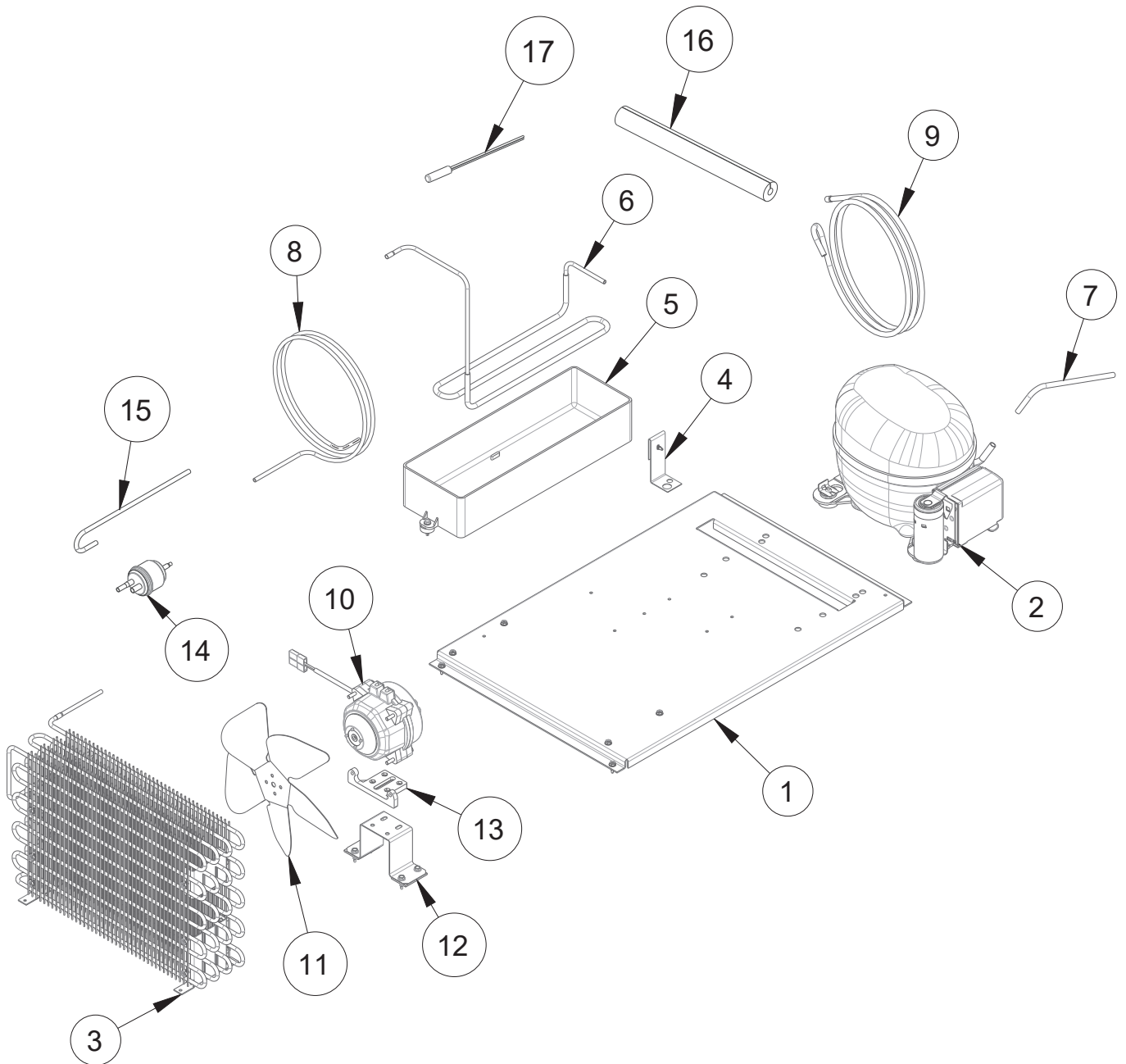

NÚMERO	DESCRIPCIÓN	CÓDIGO
1	BASE UNIDAD	2058402
2	COMPRESOR	3064499
3	CONDENSADOR	3064823
4	SOPORTE CHAROLA	2003751
5	CHAROLA CONDENSADOR	3000814
6	TUBO DE DESCARGA	2123994
7	TUBO DE CARGA	2021335
8	TUBO SALIDA COND	2123996
9	TUBO DE SUCCIÓN	2069547
10	MOTOR COND	3065293
11	ASPA MOTOR COND	3024837
12	BASE MOTOR COND	3027233
13	SOPORTE MOTOR COND	3039514
14	FILTRO DESHIDRATADOR	3043930
15	TUBO DE CARGA	2021335
16	CUBRE TUBOS ESPUMA	3068712
17	SENSOR TEMPERATURA COND	3079581

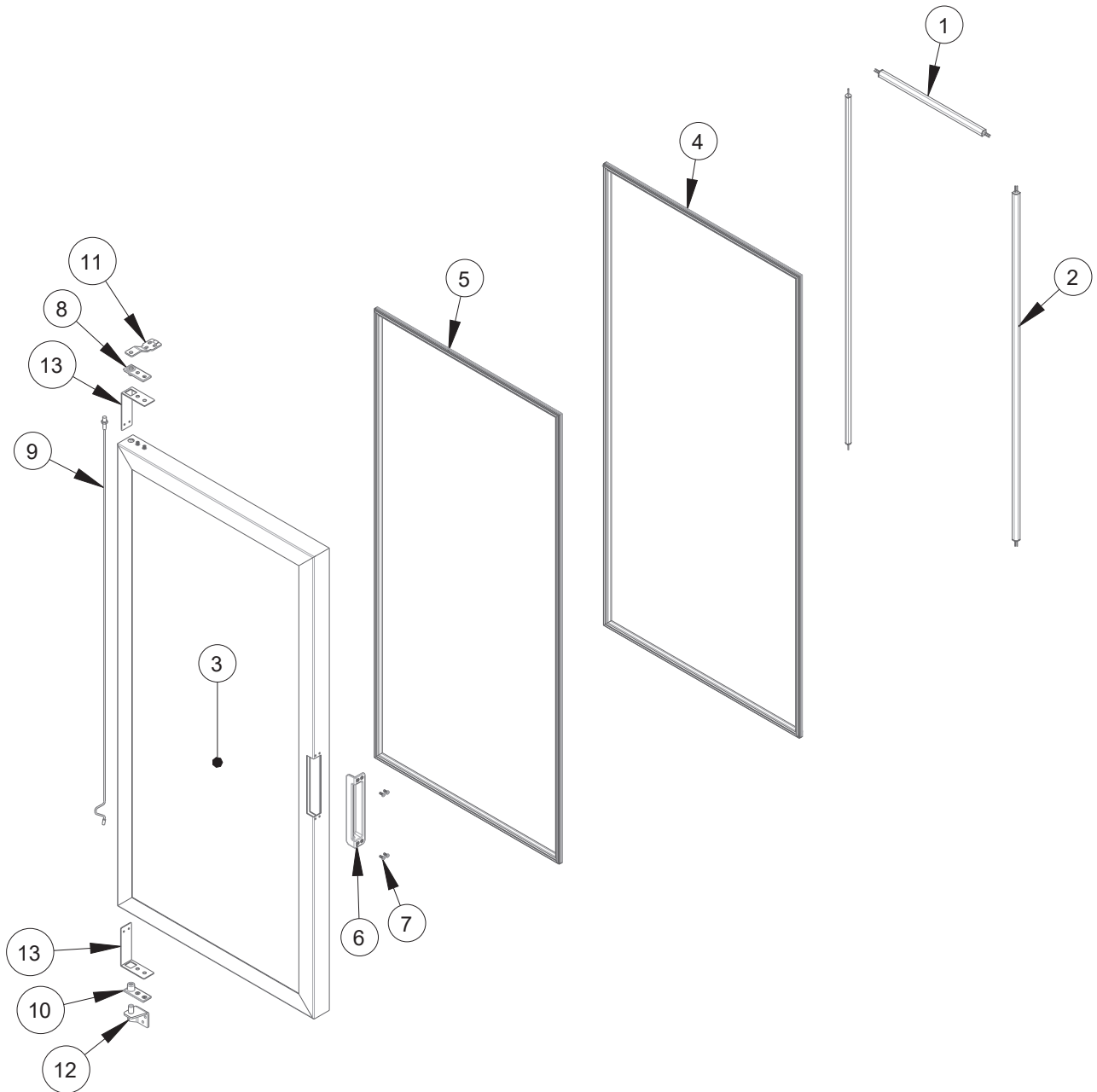



PUERTA

Explosionado Modelo TVF16

REV 01/24

NÚMERO	DESCRIPCIÓN	CÓDIGO
1	LAMPARA 4 LEDS	3061892
2	LAMPARA 16 LEDS	3061895
3	PUERTA VIDRIO DER	2123920
4	EMPAQUE MAGNÉTICO EXTERNO	3040943
5	EMPAQUE MAGNÉTICO INTERNO	3044130
6	JALADERA PLÁSTICA	3075174
7	REMACHE DESMONTABLE	3027788
8	BUJE PUERTA SUP	3031838
9	AUTOCIERRE	3066160
10	BUJE PUERTA INF	3035612
11	BISAGRA SUPERIOR	3060408
12	BISAGRA INFERIOR	3065936
13	REFUERZO PUERTA	3039720